

GLENDINNING

R/C CABLEMASTER

RV Power Cable Storage System

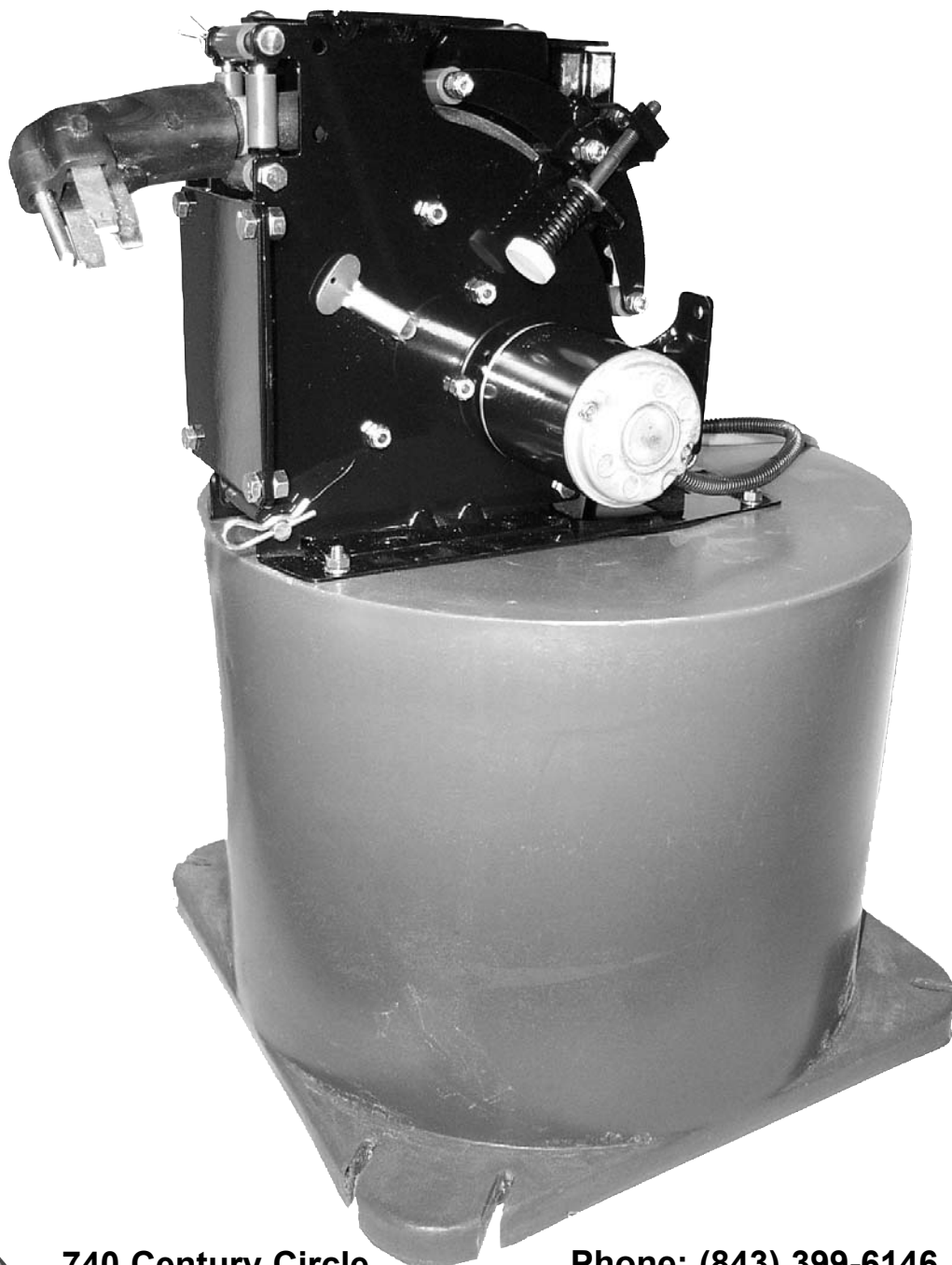

GUIDE TO:

- **DESCRIPTION**
- **INSTALLATION**
- **OPERATION**



740 Century Circle
Conway, SC 29526

Phone: (843) 399-6146

Fax: (843) 399-5005

www.glendinningprods.com

TABLE OF CONTENTS

THANK YOU...	PAGE 1
INTRODUCTION	PAGE 1
FEATURES AND BENEFITS	PAGE 2
INSTALLATION OVERVIEW	PAGE 3
Location for the RLC-Cablemaster	PAGE 3
Power Cable Exit	PAGE 3
Connection to Electrical System	PAGE 3
INSTALLATION INSTRUCTIONS	PAGE 4
WIRING INSTRUCTIONS	PAGE 4
OPERATION INSTRUCTIONS	PAGE 5
RLC-CABLEMASTER DIMENSIONS	PAGE 5
POWER CORD HAZARDS STATEMENT	PAGE 6
RLC-CABLEMASTER REGISTRATION	PAGE 6
WARRANTY	PAGE 7

INTRODUCTION

Welcome to the Glendinning family of quality products. Your new *RLC-Cablemaster* carries the same assurance of quality that has stood behind every product from Glendinning for over 30 years. Each *RLC-Cablemaster* is manufactured under the strictest standards because we are proud of our reputation for quality products and service.

This manual is intended to provide you with the basic understanding of the *Glendinning RLC-Cablemaster* and to familiarize you with the unit's installation. The *RLC-Cablemaster's* installation will depend, to a large extent, on the specific coach. Some coaches are easy, while others make it more difficult to install.

The actual installation process is straightforward and uncomplicated, with one exception—it may be necessary to modify the 120 / 240 VAC electrical wiring. **This must be done properly and carefully to assure the safety of the coach and should be handled by someone who is qualified to work on this wiring.** In some cases, this will be within the capability of the coach owner. However, if there is any uncertainty as to the proper methods of working with AC wiring, a qualified and competent electrician should do this wiring.

If the installation is done properly, following common sense mechanical and electrical principles, and if the directions contained in this manual are followed, the *RLC-Cablemaster* will provide many years of trouble-free service.

All *RLC-Cablemasters* have been designed to pay out and retract your coach's RV power cable without overloading the motor within the system's power unit. Properly adjusted, a *RLC-Cablemaster* will extend or retract the necessary amount of your RV power cable as is needed, limited only by your coach's power cable storage capacity.

The *RLC-Cablemaster* consists of two major components; the power unit and storage container. Consult the next page (2) for features and benefits. The storage container may either be an existing space or apparatus that allows the free fall and coiling of the RV power cable. Glendinning also has styrene storage containers available for purchase in a variety of sizes (see pg.14, Cablemaster Accessories).

THANK YOU...

for buying the Glendinning RLC-Cablemaster. At Glendinning, we are committed to providing you, our customer, with a product that will yield trouble-free service. Care has been taken during each phase of the manufacturing process to guarantee a lifetime of quality and performance—after all, our name is on it!



Paul

John

Paul & John Glendinning

ATTENTION:

In preparing this manual, Glendinning has relied upon the standards established by the National Electric Code and the recommended practices and standards for DC electrical systems.

This manual reflects practices and standards in effect at the time of publication and is intended only as a guide to understand the *RLC-Cablemaster*.

Glendinning will not be liable for any loss, damage, incidental or consequential damages of any kind, arising in connection with the use or reliance upon this manual.

FEATURES AND BENEFITS

RLC-CABLEMASTER

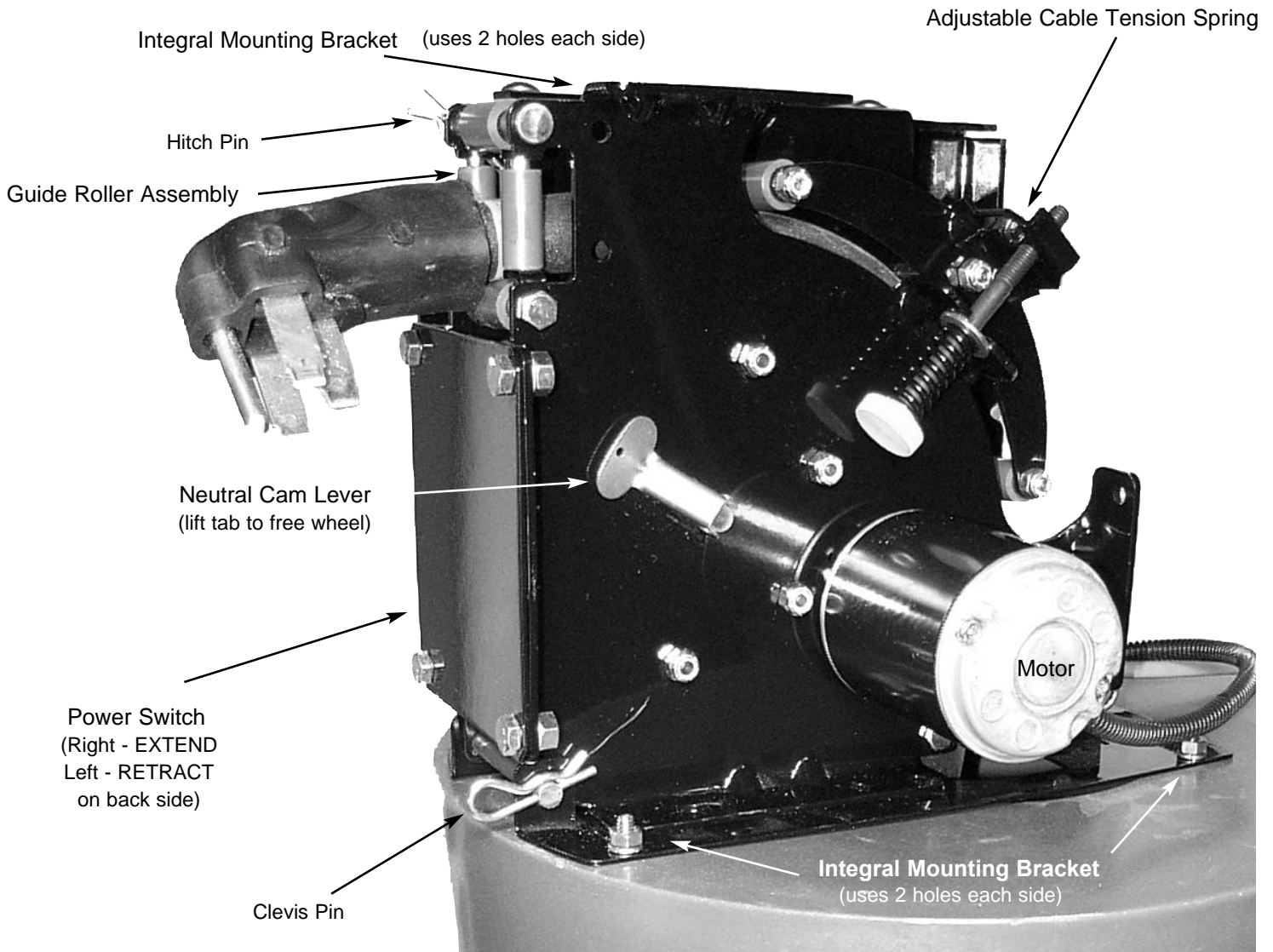

All Cablemasters are essentially the same in design and operation, however the *RLC-Cablemaster* has extra features included which give the unit enhanced operational abilities. The features and benefits are:

- 1) **Neutral Cam feature** — the *RLC-Cablemaster* has the ability to quickly “freewheel” the power pulley in emergency situations. To release, just lift the cam. To reset, turn power switch off, pull lightly on cable while pressing cam tab down.
- 2) **Easier to install existing power cable** — designed with a roller bar load spring and removeable roller guides, installing your coach’s existing power cable has never been easier (see pg. 4). Saves you time and effort!
- 3) **Adjustable Cable Tension feature** — this unique spring loaded mechanism allows for the fast, easy adjustment of cable while maintaining steady loads on the cable which provides safe, slip-free operation even in extreme weather conditions.
- 4) **Unmatched Versatility** — the *RLC-Cablemaster* takes up less space and can handle as much cable as your storage area will allow. Stop running out of cable — go the distance!

The *RLC-Cablemaster* comes with integral mounting brackets for easy installation to the wall or top of your storage bay. The power unit can also be easily mounted to the cable storage container (Glendinning also stocks a variety of styrene containers) and installed as a “package” unit.



INSTALLATION OVERVIEW

BEFORE installing your *RLC-Cablemaster*, consider the following three points:

Storage Bay
16"wx14"dx21"h
Space typically
needed for *RLC-*
Cablemaster

1 LOCATION FOR THE *RLC-CABLEMASTER* :

The first step in determining where to locate your *RLC-Cablemaster* should be finding a suitable space where the cable will be stored when it is not in use. This location must be protected from the weather and must not contain combustible fuels.

The typical size requirement for the *RLC-Cablemaster* is 16" W x 14"D x 21"H with the Power Unit mounted directly above the cable storage area.

It must be emphasized that the Power Unit does not have to be mounted to the container. In limited space areas the Power Unit may be mounted separately. Many coach owners have successfully installed the *RLC-Cablemaster* deep within the coach's interior by utilizing extensions that allow the power cable plug to exit the side or floor of the exterior.

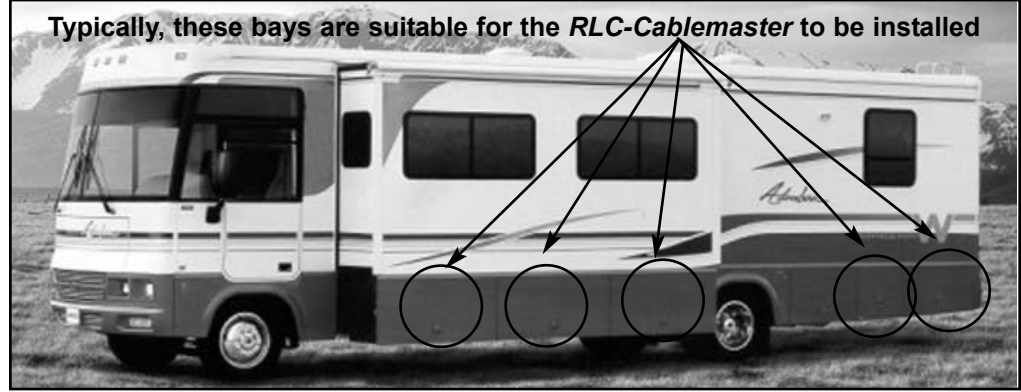

Typically, these bays are suitable for the *RLC-Cablemaster* to be installed

The approximate size for 35 feet of cable storage is an area about 14" wide by 16" deep by 13" high. This space can vary somewhat in both size and shape (square, circular or rectangular).

2 CABLE PLUG EXIT :

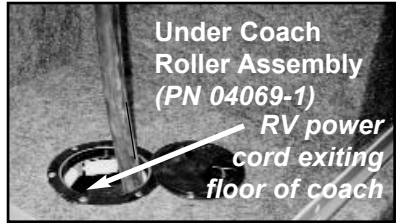

Under Coach Roller Assembly (PN 04069-1)
RV power cord exiting floor of coach

The second step is determining where the cable plug will exit the interior of the coach. In many coaches, the cable exits through an access hole on the bottom of the cable storage area or electrical hookup bay (see photo at left). In other cases, the power cable may exit the side of the coach through a new or existing access door (similar to a fuel door, see above). In either case, a route must be identified that the cable will take from where it is stored to the outside of the coach.



RV POWER CORD PLUG & *RLC-CABLEMASTER*
Access Door Exit

3 CONNECTION TO THE COACH ELECTRICAL SYSTEM :

A common misunderstanding concerning the installation of the *RLC-Cablemaster* is how the unit is connected to the coach's electrical system. The drawing below demonstrates how this is accomplished.

The blunt cut end of the RV power cable (supplied with the *RLC-Cablemaster*) should exit a hole in the bottom of the container. This end should be connected to the Power Transfer Switch which automatically switches power for your coach's electrical system between the on-board generator and the RV power cable hook-up.

The *RLC-Cablemaster* is now "hard-wired" to your coach's electrical system. It is no longer necessary to use the power cord connection that was part of your RV's power system. The power cable of the *RLC-Cablemaster* is all you need.

The power cable must be connected to the coach AC electrical system in accordance with the instructions contained in the National Electrical Code. Secure cable to storage area to ensure that no strain will be placed upon the power cable connection to the electrical system.

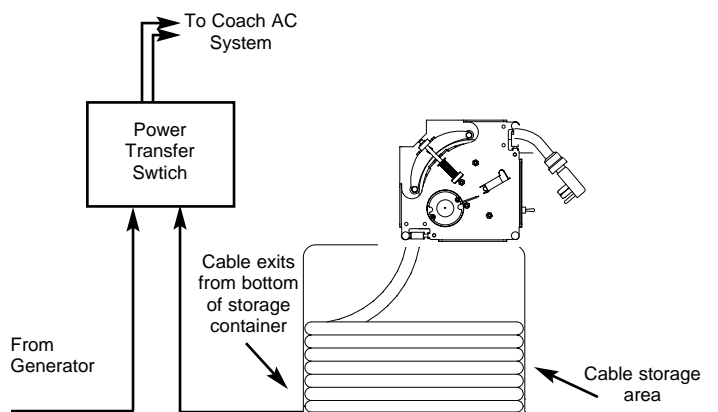



INSTALLATION INSTRUCTIONS

The *RLC-Cablemaster* is designed to allow existing routed cable to be installed quickly.

- A. Loosen the cable tension spring and remove the long bolt from the slotted bracket.
- B. The roller cage can now be removed from the frame.
- C. Pull the hitch pin from the clevis bolt, and remove the bolt and rollers.
- D. Now throw the cable into the pulley groove.
- E. RE-Install clevis bolt and rollers to capture cable.
- F. Reinstall the roller cage into slot on backflange and reinstall long bolt into slotted bracket.
- G. Turn tension bolt to desired setting and test (Cable should move as pulley turns, all rollers touching the cable should turn freely).

The *RLC-Cablemaster* system must be mounted in a location that is protected from the weather and that does not contain combustible fuels. Generally, the existing compartment where the storage cable is currently being stored is an acceptable location.

MOUNTING OVERHEAD OR TO REAR WALL OF STORAGE AREA:

In general, the *RLC-Cablemaster* system will be suspended from the overhead of the compartment where it will be located by using the integral mounting bracket holes on the top of the *RLC-Cablemaster*. The unit may also be installed to the rear wall of the storage area by using a mounting bracket adapter plate (contact Glendinning). To install the *RLC-Cablemaster* center the cable guides on the storage space. Secure the unit by using four (4) 1/4" diameter carriage or lag bolts (grade 5 or better). If carriage bolts are used, locknuts / lock washers should also be used to prevent unintended loosening.

MOUNTING TO CONTAINER:

The *RLC-Cablemaster* system may also be attached to a suitable storage container by using the mounting holes at the bottom of the unit. Locate an existing storage compartment that will accommodate the unit's overall height. Simply slide the unit into the existing space and secure container to floor of storage area (before securing container make sure ample power cord exits the bottom of the container for wiring to coach electrical system).

You are now ready to connect the *RLC-Cablemaster* to your coach's electrical system.



WIRING INSTRUCTIONS

WARNING: If you are not familiar with the standards and practices for DC electrical systems, it is **STRONGLY RECOMMENDED** that you contact a qualified electrician before proceeding.

The *RLC-Cablemaster* comes with (2) 14 gauge wires attached to the motor via the power switch assembly. These wires should be connected to the 12VDC power source.

The white wire should be connected to the positive terminal (+) and the black wire should be connected to the negative terminal (-).

It is **IMPORTANT** to install a 20 amp fuse close to the power source in-line with the white wire. This installation will prevent damage to your coach.

Make sure all connections are secure.

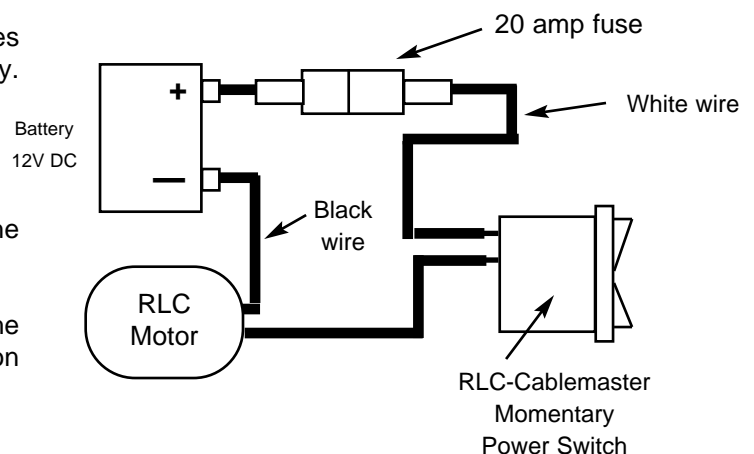



OPERATION INSTRUCTIONS

To operate the *RLC-Cablemaster*:

- 1) Hold the power switch in the desired direction (IN / OUT).
- 2) Release the switch when desired cable length has been achieved or at end of cable travel (stop collar).

To adjust the *RLC-Cablemaster* cable roller load:

- 1) Turn bolt to increase / decrease cable tension. Test cable tension (cable tension may be increased for winter operation).



RLC-CABLEMASTER DIMENSIONS

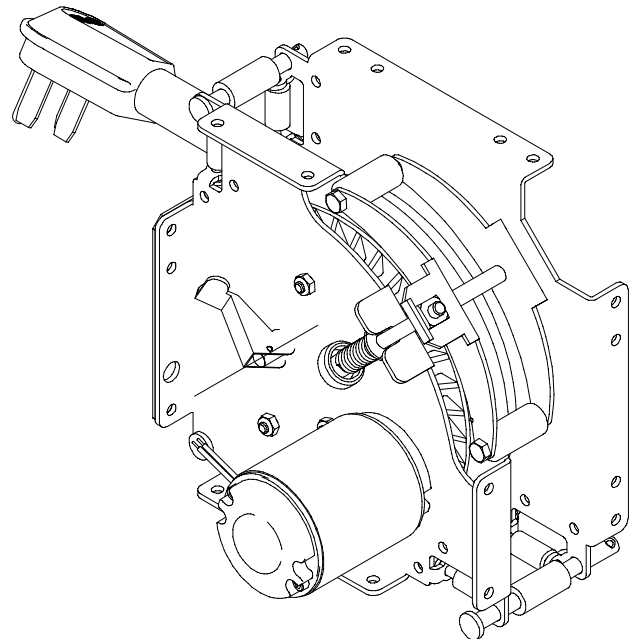
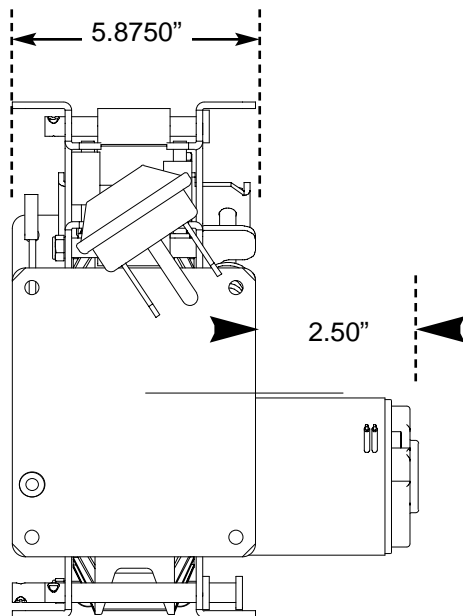
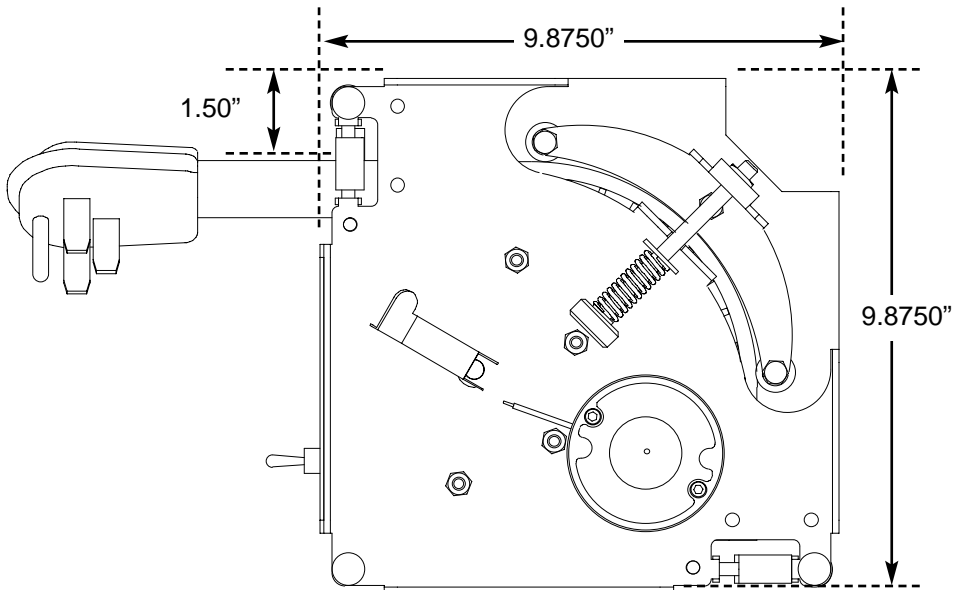



POWER CORD HAZARDS STATEMENT

DANGER: ELECTRICAL CORD REELS CAN BE HAZARDOUS. MISUSE CAN RESULT IN FIRE OR DEATH BY ELECTRICAL SHOCK. PLEASE READ CAREFULLY AND FOLLOW INSTRUCTIONS:

- A cord reel marked for indoor use is to be used indoors only.
- Inspect thoroughly before each use. DO NOT USE if damaged.
- Look for the number of watts or amperes on appliances to be plugged into cord reel.
- See label on cord reel for specific watts or amperes.
- DO NOT plug more than the specified number of watts or amperes into this cord reel.
- DO NOT run through doorways, holes in ceilings, walls or floors.
- Make sure appliance is OFF before connecting cord reel to outlet.
- FULLY INSERT plug into outlet.
- DO NOT remove, bend or modify any metal prongs or pins of cord reel.
- DO NOT use excessive force to make connections.
- DO NOT connect a three-prong plug to a two-prong cord reel.
- Keep away from water.
- DO NOT USE WHEN WET.
- Keep children and pets away from cord reel.
- DO NOT plug one cord reel into another.
- AVOID OVERHEATING.
- DO NOT cover with any materials.
- DO NOT drive, drag, or place objects over cord.
- DO NOT walk on cord.
- GRASP PLUG to remove from outlet.
- Always store cord reels INDOORS.
- Always unplug when not in use.
- DO NOT unplug by pulling on cord.

THIS IS A POLARIZED CORD REEL



RLC-CABLEMASTER PRODUCT REGISTRATION

Please take a moment to validate your product warranty by mailing in this card with the proper information.

FOLLOW THESE SIMPLE STEPS :

- STEP 1: Fill in the registration card.
- STEP 2: Cut along dotted line.
- STEP 3: Affix correct postage.
- STEP 4: Drop in mailbox.

OR SEND VIA FAX TO:

(843) 399-5005



RLC-CABLEMASTER WARRANTY REGISTRATION



NAME

ADDRESS

CITY STATE ZIP

COUNTRY PHONE EMAIL

COACH MODEL & YEAR OF MANUFACTURE WOULD YOU LIKE TO RECEIVE INFO ON
NEW PRODUCTS FROM GLENDINNING?

RLC-CABLEMASTER SERIAL NUMER YES NO

WHAT WOULD YOU LIKE TO SEE IMPROVED / CHANGED? **THANK YOU!**

WARRANTY

PRODUCT COVERED BY THIS LIMITED WARRANTY: RLC-CABLEMASTER

1. *GLENDINNING MARINE PRODUCTS, INC.* warrants to the original consumer purchaser that the RLC-Cablemaster will be free from defects in material and workmanship under normal use and service for a period of one (1) year from the date of purchase.
2. *This LIMITED WARRANTY applies to* defects in material and workmanship. It does not apply to chromeplated or anodized finish or to power cable damage caused by inadequate cable storage area or installation not in accordance with *GLENDINNING MARINE PRODUCTS, INC.* specifications.
3. *This LIMITED WARRANTY is void* if the product has been damaged by accident or unreasonable use, neglect, improper installation, or other causes not arising out of defects in material or workmanship.
4. *To obtain performance of this LIMITED WARRANTY* obligation the original purchaser should contact *GLENDINNING MARINE PRODUCTS, INC.* for instructions concerning removal and shipping of the defective component. Upon compliance of the foregoing procedure all warranted defects will be repaired, or at *GLENDINNING MARINE PRODUCTS, INC.* option, the complete unit replaced and returned to the consumer, shipping charges prepaid.
5. *GLENDINNING MARINE PRODUCTS, INC.* does not assume the costs of removal and/or installation of the product or any other incidental costs which may arise as a result of any defect in materials or workmanship.

THIS WARRANTY IS IN LIEU OF ALL OTHER EXPRESS WARRANTIES. ANY WARRANTY IMPLIED BY LAW INCLUDING WARRANTIES OF MERCHANTABILITY OR FITNESS, IS IN EFFECT ONLY FOR THE DURATION OF THE EXPRESS WARRANTIES SET FORTH IN THE FIRST PARAGRAPH ABOVE. NO REPRESENTATIVE OR PERSON IS AUTHORIZED TO GIVE ANY OTHER WARRANTY OR TO ASSUME FOR *GLENDINNING MARINE PRODUCTS, INC.* ANY OTHER LIABILITY IN CONNECTION WITH THE SALE OF IT'S PRODUCTS. *GLENDINNING MARINE PRODUCTS, INC.* WILL NOT BE LIABLE FOR ANY CONSEQUENTIAL DAMAGES RESULTING FROM THE USE OR INSTALLATION OF IT'S PRODUCTS.

PRODUCT WARRANTY INFORMATION

PLACE
STAMP
HERE



**740 CENTURY CIRCLE
CONWAY, SC 29526-8274
USA**

PRINT DATE: 01/03